



## JAWAHAR NAVODAYA VIDYALAYA,

VALPOI, NORTH GOA - 403 506

### **E – Tender Notice 2017-18 – 02**

Sealed and covered tenders are invited for Jawahar Navodaya Vidyalaya, Valpoi, North - Goa for the period from Jan-2018 to Dec--2018. **Eligible Tenderers**, Central Govt. & Semi Govt. Agencies, Registered and Reputed Firms/Companies, Authorized Dealers, Small Industries Unit, Experienced retailers, distributors dealing with the particular class of goods registered with sales Tax/CST/VAT(TIN)/GST and with upto date GST/VAT, Income Tax & Professional Tax clearance may participate in the tender for the supply of below mentioned items.

All the sealed tenders must be duly supported & tagged with necessary certificates and SBI Draft of Earnest money in favour of Principal, Jawahar Navodaya Vidyalaya, Valpoi, North Goa.

Tender Paper will be available from **06.01.2018 to 22.01.2018** on all working days from **10.00 Hours to 16.30 Hours** and tender will be accepted upto **11.00 AM of 22.01.2018**. Tender paper will be accepted through registered post or dropped by hand in the sealed Tender Box kept in the Vidyalaya Office. **Anybody downloading the form from vidyalaya website “[www.jvnorthgoa.gov.in](http://www.jvnorthgoa.gov.in)” or Central Public Procurement Portal (CPPP) [www.eprocure.gov.in](http://www.eprocure.gov.in) will pay the cost of tender paper along with earnest money in a separate demand draft.**

Tender will be opened at **11.30 A.M.** on **22.01.2018** in the Office of the Principal, JNV, Valpoi, North Goa. PAC reserves the right to verify the quality of the items and accordingly can accept or reject any tender.

S. No.	Name of Item	Earnest Money	Cost of Tender Paper- ( Non - refundable )
01	Furniture	Rs.2000.00	Rs.100.00
02	Other Equipments	Rs.2,000.00	Rs.100.00
03	Sports Equipments	Rs.1000.00	Rs.100.00
04	Dispose of Scrap/ Condemned Items	Rs.1000.00	Rs.100.00

**PRINCIPAL**  
JNV- Valpoi , North - Goa

**JAWAHAR NAVODAYA VIDYALAYA, VALPOI, NORTH - GOA.**  
**TENDER INVITATION FORM**

Ref . No. E-Tender /JNVNG /2017-18/

Date - / /2018

To,

M / S. -----  
 -----

Sub: TENDER FOR THE SUPPLY OF \_\_\_\_\_

As requested by you blank tender forms is /are enclosed herewith for the above items(s) duly filled in and signed tender forms must be submitted up to **11.00 hours of 22 /01 /2018.**

Sealed tenders for the supply of the articles shown in the attached statement are invited by the undersigned on behalf of Jawahar Navodaya Vidyalaya, Valpoi, North Goa. Tenders should be sent under strong sealed cover by Registered post or to be dropped in the tender box kept in the vidyalaya and marked as tender for the supply of \_\_\_\_\_ and not by name. The tender will be opened in the Chamber of the undersigned at **11.30 AM on 22 /01 /2018.**

The tenders shall be submitted according to the terms & conditions specified in Para 01 to 15. Unless specified otherwise in the tender, it shall be considered that the terms & conditions stipulated here under have been agreed to.

**TERMS & CONDITIONS**

01. The rates should be including freight/transportation and should include excise duty, sales tax and any other taxes, or imposition whatever liable in respect of the supplies. **The rates quoted should not be more than MRP and or prevailing Market Rates**

02. There should not be any over-writing or corrections in the tender. If a figure is to be amended, it should be neatly scored fresh figure written & correction to be attested with date. In the absence of the attested signature the tender is liable to be rejected.

03. Jawahar Navodaya Vidyalaya, Valpoi does not bind itself to accept the lowest tender and reserves the right to accept the tender in whole or in part i.e., with respect to all the articles mentioned in the attached statement or in respect of anyone or more than one articles specified in the attached statement as Vidyalaya may decide

04. On acceptance of the tender it will become a contract and the contractor, shall be bound by the terms and conditions of the tender under the provisions of GFR.

05. The person/persons, whose tender is accepted, hereinafter called the contractor shall deposit an earnest money as shown below along with tender which shall be refunded in the event rejection of the tender. The earnest money will be forfeited in the event of failure to comply with the contract. In the event of the tender being accepted, the earnest money will be adjusted towards Security Deposit, which shall be, payable at the rates mentioned below.

**Security Deposit at 10% of the total amount**

If the contractor is not agreeable to pay Security Deposit the reasons therefore should be specified and the undersigned reserves the right to accept or reject the request.

06. If the contractor fail to supply the articles within the time stipulated in the letter of acceptance by the undersigned, the undersigned shall be at the liberty to purchase the articles from the market or get the rest of the contract completed by any other person or firm and the difference of price, if any, shall be deducted from the earnest money/security deposit and in case any amount in excess of security deposit paid by the undersigned the contractor shall be liable to pay the amount.

07. The quantity of the articles indicated in the attached statement may be increased or decreased at the discretion of the undersigned without assigning any reason.

08. Prior to acceptance of the tender, the undersigned reserves the right to call for samples and demonstration and the contractor shall be liable to supply the samples or give the demonstration free of cost. In case of furniture, the contractor shall be require to fix a metal label on the furniture supplied by him giving his/her name & year of manufacture.

09. In the event of the acceptance of the tender when placing of the order, for purchase, the articles ordered for would be subjected to an inspection by the undersigned or Verification Committee and are liable to be rejected if the articles supplies are not according to approved samples or do not confirm to the specification prescribed.

10. The rates quoted in the tender shall hold good up to **31. 12. 2018. No amendment in the rates will be accepted.**
11. The amount of security deposit shall be retained by the Vidyalaya for a period of six months from the date of completion of supplies as a safeguard against any defect appearing in the articles supplied within this period.
12. Tenders which do not comply with the above conditions are liable to be rejected.
13. Material quoted must be supplied at JNV campus (**door delivery**)
14. Please supply sample of the material/ items along with tender.
15. Along with the tender forms, the following documents are to be attached.
1. Shop Act Registration/ License copy.
  2. Sale tax/VAT/GST Registration copy
  3. Income tax clearance>Returns file copy
  4. If any past experience, attach copy of proof.
  5. Attach separate EMD for each category as per amount mentioned
  6. PAN / TAN /GST No. and Proof. [Xerox copy]

The Earnest Money based on the requirement of the items will be as under and will required to be enclosed with the tender by way of Demand Draft / Banker cheque drawn in favour of The Principal, Jawahar Navodaya Vidyalaya, Valpoi- Goa . We bank with State Bank of India, at Valpoi. – Goa. IFSC Code NO. of Bank – **SBIN0006432.**

S.NO	HEAD	EMD RS	S.NO	HEAD	EMD RS.
01	Furniture	2000/-	02	Other Equipments	2000/-
03	Sports Equipments	1000/-	04	Dispose of scrap/ condemned items	1000/-

STATION JNV-VALPOI

DATE: / / 2018

PRINCIPAL  
JNV-VALPOI –NORTH-GOA

**For Tenderer [signature & Address]**

All the above conditions are accepted by me /us.

SIGNATURE :-  
NAME :-  
Full Address :--  
Phone No. :-  
Station :-  
Date :-  
Seal :-

**JAWAHAR NAVODAYA VIDYALAYA, VALPOI- NORTH-GOA**  
**TENDER FOR THE SUPPLY OF FURNITURE ITEMS FOR 2017-18**

SR .NO.	PARTICULARS OF ITEM	Rate	Remarks
1	<b>DESK</b> [ for smart room ] Specification – supply & installation of smart room desk using material of 1” x 1” MS square tube frame of 1.6 guage and 25mm x 25 mm x 3 mm MS angle for frame and should be powder coated. 19 mm, 1 st Quality of marine ply of 710 ISI mark 19mm and branded company. 0.8 laminate sunmica should be fixed on ply and frame of desk top should be flat and size of Bookshelf H-6” . size- L- 46 ” x B- 18” x H -28 ” [ as per drawing attached ]	Rs.	
2	<b>BENCH</b> [ for smart room ] Specification - supply & installation of smart room bench using material of 1” x 1” MS square tube frame of 1.6 guage and 25mm x 25 mm x 3 mm MS angle for frame and should be powder coated 1st Quality of marine ply of 710 ISI mark 19 mm branded company 0.8 laminate sunmica should be fixed on ply and frame of bench top for seat. Size- 46” x 12” x 18 ” H [ as per drawing attached ]	Rs.	
3	<b>FRONT OFFICE COUNTER.</b> Specification – supply & installation of office counter using material of 19 mm 1 st quality of marine ply of 710 ISI mark of branded company using of 0.8 mm laminate sunmica fixed on ply. Seating arrangement of 5 Nos. of staff for compartment of 46.5 “ each and should be arrangement of one drawer , one cupboard with middle partition in the cupboard and one key board for each compartment & locking system with front side 12 mm Glass on Top of 16” Height SIZE- 237”X 30 “ X 32” [as per drawing attached]	Rs.	
4	<b>EXECUTIVE CHAIR</b> [standard size] 1. Branded Co. 1. 2. 3.	Rs Rs RS.	
5	<b>DINNING TABLE</b> Wooden frame size – L- 66” x B- 30” X W- 4” by 1.5” with down 2 support of 2” x1.5” and leg thickness size 3” x 3 ” down support and using material of 19 mm 1 st quality of marine ply of 710 ISI mark of branded company using of 0.8 mm laminate sunmica fixed on ply for Top. Size- 72 ” X 36 ”x 31 ” H. Type of wood - Matti / Teakwood [as per drawing attached]	Rs.	
6	<b>DINNING BENCH</b> Wooden frame of L- 30 ” x B- 8 ” x w - 2” by 1.5” and leg thickness size 2” x 2 ” with down support 2”x2” and using material of 19 mm 1 st quality of marine ply of 710 ISI mark of branded company using of 0.8 mm laminate sunmica fixed on ply for Top. Size – 36” x 12 ” x 18.5 ” –H Type of wood -Matti / Teakwood [ as per drawing attached]	Rs.	

Enclosed – EMD of Rs. ----- vide DD. No. -----Dated ----- of----- Bank

DATE :  
PLACE :

SIGNATURE,  
NAME & COMPLETE ADDRESS OF THE FIRM  
WITH RUBBER STAMP & PHONE NO..



① DESK - 46" x 18" x 28" x 75 cm

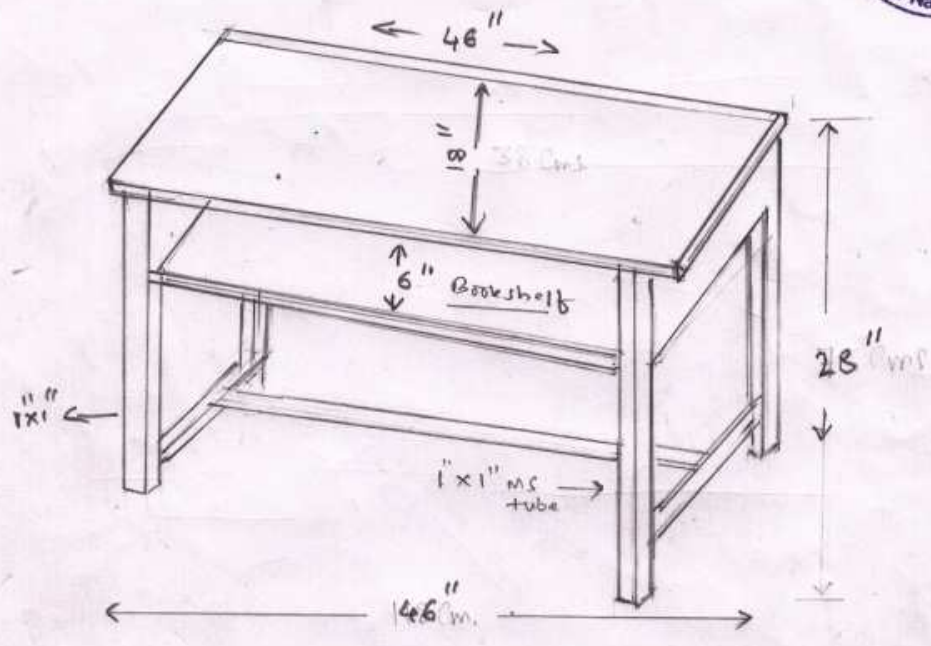

② BENCH - Size 46" x 12" x 18"

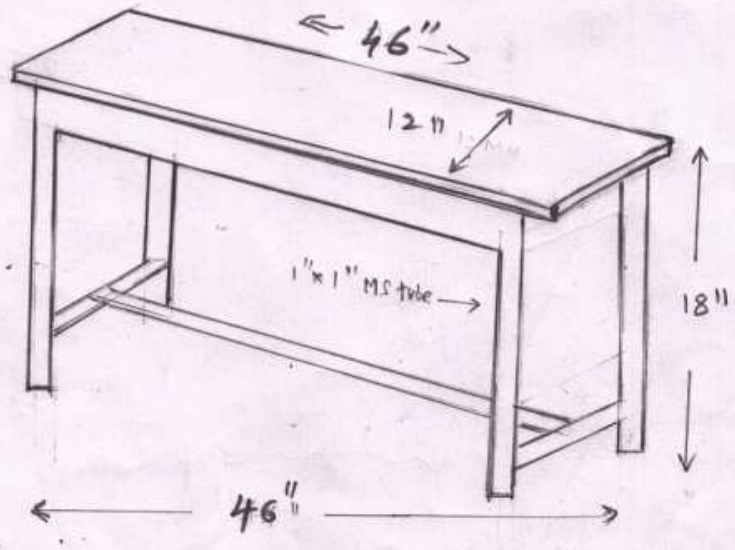



3

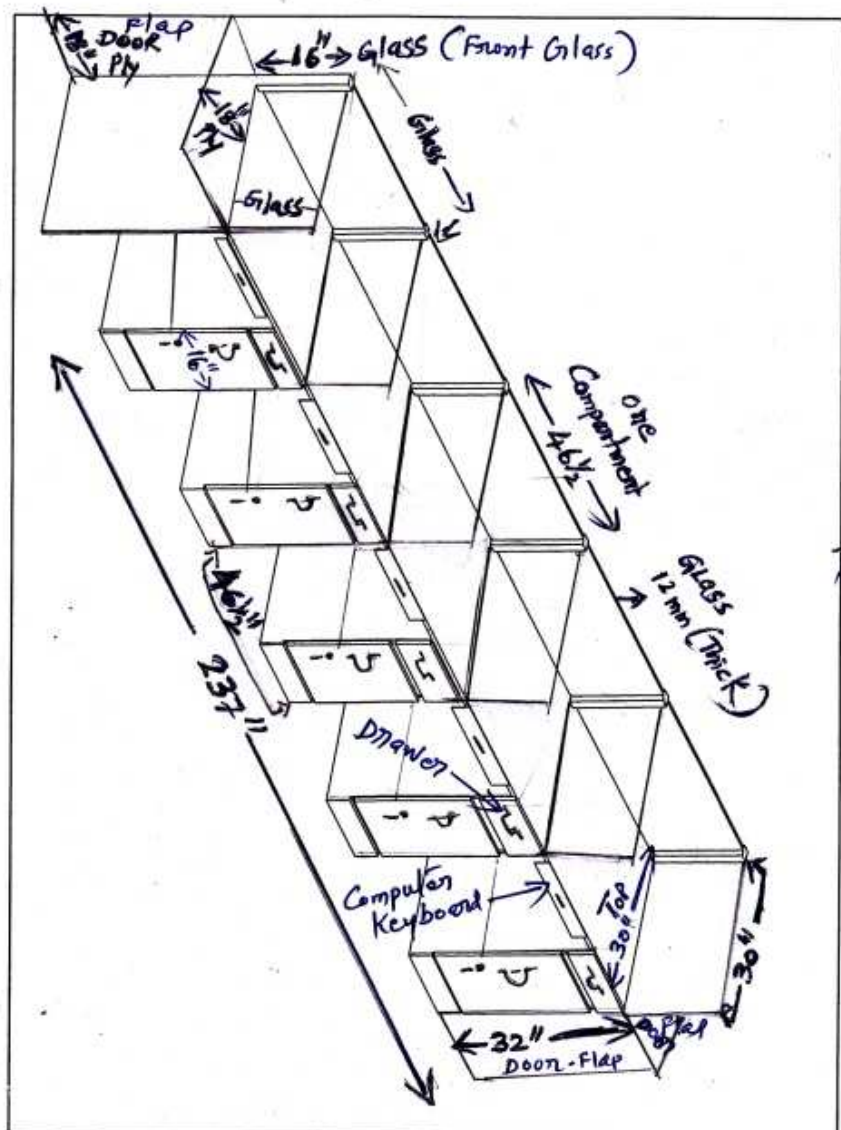

FRONT OFFICE COUNTER (with front side glass)

✓



DINNING TABLE 72" x 36" x 31"

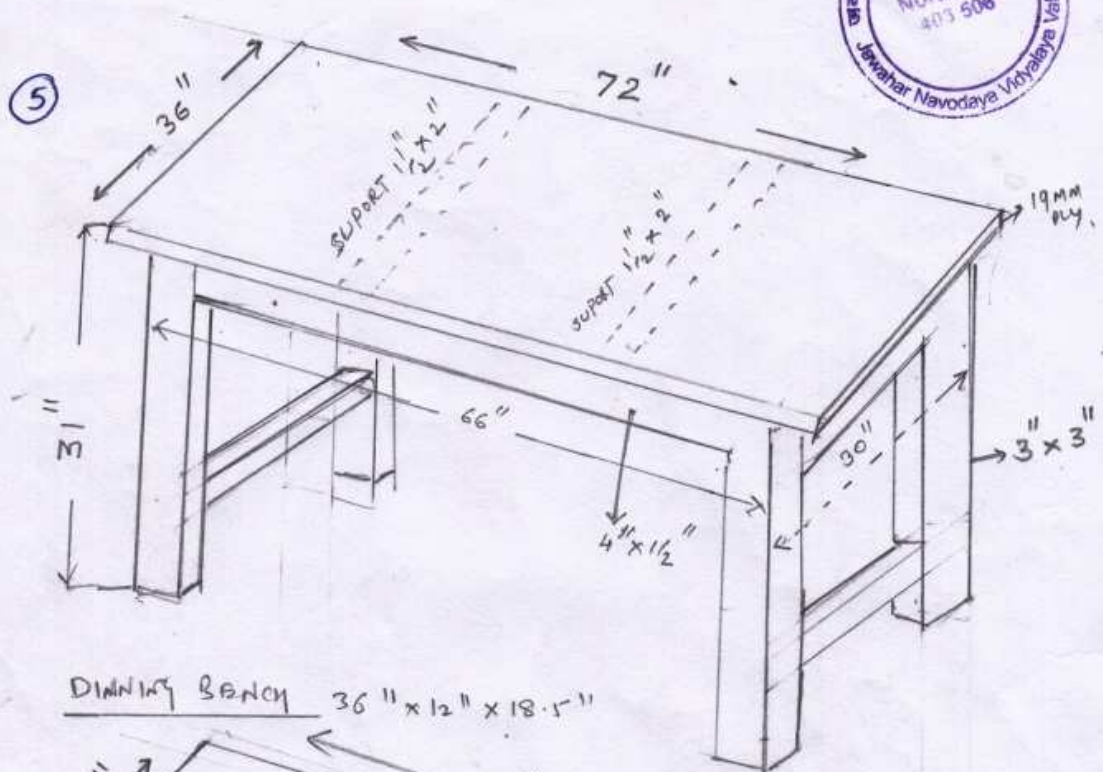

DINNING BENCH 36" x 12" x 18.5"

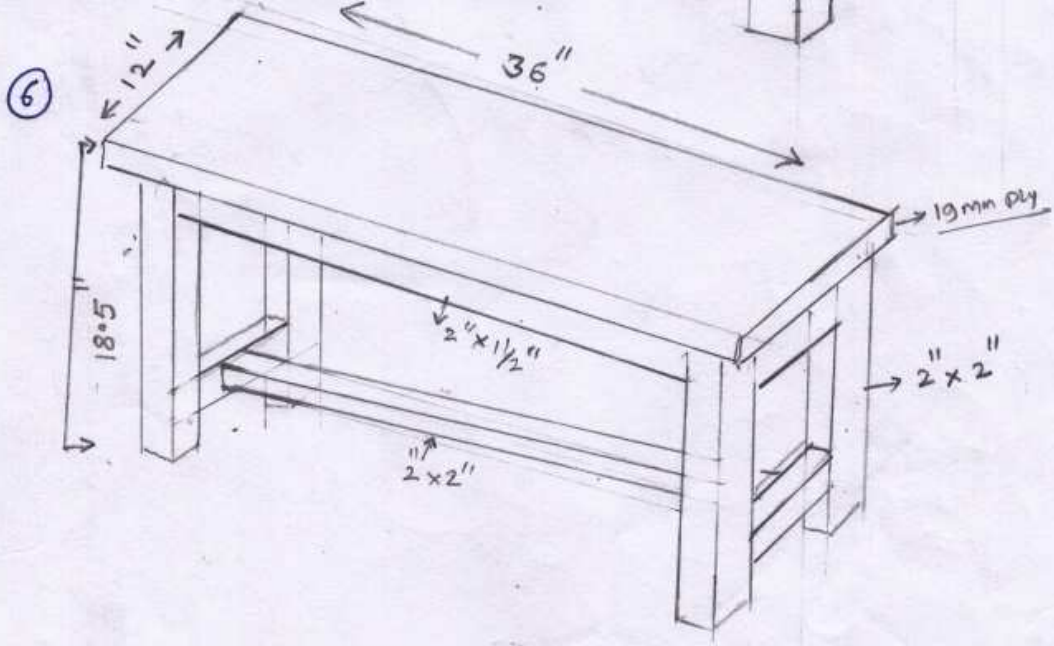

**JAWAHAR NAVODAYA VIDYALAYA, VALPOI- NORTH-GOA**  
**TENDER FOR THE SUPPLY OF OTHER EQUIPMENTS ITEMS FOR 2017-18**

SR NO.	PARTICULARS OF ITEM	Rate	Remarks
1.	<u>AIR CONDITIONED [AC] WITH INSTALLATION</u> 1 .LLOYD CO. 1.5 Ton 3 star BEE Rating 2017 split Ac-White [LS19A3B/HR] Copper condenser	RS.	
	2. VOLTAS CO. 1.5 Ton 3 star BEE Rating 2017 split AC White [ 183LYe ]	RS.	
	3 .DAIKIN CO. 1.5 Ton 3 star BEE Rating 2017 split Ac-White [ FTC50RRV16/161, Copper condenser]	RS.	
2.	STABILIZER FOR 1.5 TON, 3 STAR AC <b>V - GUARD</b> OR ANY OTHER REPUTED BRAND	RS.	
3.	<u>DESERT COOLER –</u> 1.SYMPHONY CO. Diet 22 I , Tower Air Cooler [ White ,22 Litres , 3 speed setting ]	Rs.	
	2 .VOLTAS CO.- VM- T 35 MH , Tower Air Cooler [ White , 35 Litres3 speed setting ]	Rs.	
	3 CROMPTON CO - Mystique DLX Tower Air Cooler [ Grey , 34 Litre s 2 speed setting ]	Rs.	
4.	<u>WATER STORAGE TANK - 100 LITRES CAP.</u> made out of 18 guage Stainless steel sheet (304 grade With Nelco 1.5 Taps – 2 Nos. , 1.5 ” Round SS stand Tank size- 24”x24”x12” Stand size - 24”x24”x36”	Rs.	
5.	<u>WATER HEATER BUMB/ BOILER</u> <u>Heavy duty – 200 Litres cap.</u> Diameter – 20” approx. / Bottom – 24 ” approx. Height - 62” /Inlet – 1.5” –approx /outlet – 1.5” –approx /Air pipe – 0.5” approx./Thickness- 8mm/ Jindal steel.	Rs	

Enclosed – EMD of Rs. ----- vide DD. No. ----- Dated -----  
 Of ----- Bank

DATE :  
PLACE :

SIGNATURE 11  
NAME & COMPLETE ADDRESS OF  
THE FIRM WITH RUBBER STAMP & PHONE NO.



<b>JAWAHAR NAVODAYA VIDYALYA, VALPOI, NORTH- GOA, GOA</b>					
<b>TENDER FOR THE SUPPLY OF SPORTS ITEMS [2017- 18]</b>					
<b>S. No.</b>	<b>ITEMS</b>	<b>BRAND</b>	<b>SPECIFATIONS</b>	<b>RATE</b>	<b>Remarks</b>
1	KNEE CAPS	NIVIA	Flexible Knee Support( blue)		
2	ANKLES	NIVIA	AS-588 Anker support (slip -in - style , L,M,XL,XXL)		
3	ELBOW	NIVIA	PR-3059, M, L, XL, XXL		
4	KABBADI SHOES	NIVIA	KB-118,(4,5,6,7,8,9,10 & 12)		
5	KABBADI JERSSEY WITH SHORTS	SHIV NARESH	30, 32,34,36,38,40,42		
6	STOP WATCH[MANUAL]	ONE TIGRIS	MECHANICAL STOP WATCH		
7	ELECTRONIC[WATCH]	NIVIA	JS 307		
8	FOOTBALL SHOES	NIVIA / SPARTEN	FB -1026-1		
9	FOOTBALL SUPPOTER	OMTEX	Tokyo Supporter - Back Covered - Grey		
10	FOOTBALL NET	NIVIA	FB-5606		
11	FOOTBALL STOCKING	NIVIA	Football Socks (Stockings) - Large		
12	FOOTBALL JEREESY WITH SHORTS	NIVIA	2035,		
13	FOOTBALL GOAL KEEPER GOLOVES	NIVIA	GG-881,883,893		
14	SHIN GUARD	NIVIA	SG-760 VORTEX,765- VEGO		
15	BASKET BALL RING	NIVIA			
16	FOOTBALL	NIVIA	BLACK AND WHITE FB-278		
17	CHESS WITH CHESSBOARD	EKTA	JR.FAMILY GAME		
18	SKIPPING ROPE[10 FITNESS]	VENIX	PVCROPE PLASTIC UNBEREAKABLE		
19	MEASUREMENT TAPE[100M]	FREEMA NS	Open Reel 100 Meter Fiberglas Platika Measuring Tool		
20	VOLLEYBALL	NIVIA	VB-477		
21	JAVELIN[FIBER/WOODEN ] MEN &WOMEN	NIVIA	600 , 800 Gms		
22	CRICKET SEASON BAT [LEATHER]	SS/SG	SS/SG KASHMRI WILLIOW		
23	CRICKET TENNIES BAT	SS/SG	SS/SG KASHMRI WILLIOW		
24	BATMINTON BALL	NIVIA			
25	HIGH JUMP BAR	NELCO	ALUMINUM		
26	CRICKET NET[COTTON] STDSIZE[	NIVIA	Cricket Net Blue 100ft [30.3m] x 10ft[3.03m] Netting		

S. No.	ITEMS	BRAND	SPECIFATIONS	RATE	Remarks
27	CRICKET NAYLON SIZE	NIVIA	NYALON STDSIZE		
28	CERTIFICATE		MEDIUM SIZE		
29	MEDELS, TROPHY		NK-1441,5CM( GOLD, SILVER, BRONZE		
30	FOOTBALL NET (WOMEN)	NIVIA	FB-5605		
31	FOOTBALL WOMEN	NIVIA	FB-296		
32	FOOTBALL GOAL POSTS		STANDARD SIZE FOR MAN & WOMEN [for high school goal post]		
33	BATMINTON NET 1. NYLON 2. COTTON	NIVIA BR.	Standard size.		
34	BATMINTON SHUTTLE COCK	NIVIA BR.	Standard size.		
35	HOCKEY STICK	36 "" 33 "	NIVIA CO.		
36	HOCKEY BALL -[CORK]	NIVIA CO.			
37	BALL BATMINTON NET	NIVIA CO.	Standard size.		

Enclosed – EMD of Rs. ----- vide DD No. -----Dated -----Of ----- Bank

SIGNATURE

DATE:  
PLACE

NAME & COMPLET ADDRESS OF THE  
FIRM WITH RUBBER STAMP PHONE NO.

**JAWAHAR NAVODAYA VIDYALAYA, VALPOI-NORTH-GOA**  
TENDER FOR DISPOSAL OF CONDEMNED ITEMS - 2017-18

PROFORMA FOR OFFERING RATES FOR DISPOSAL OF CONDEMNED ITEMS

AMOUNT OF EARNEST MONEY RS. \_\_\_\_\_ RUPEES \_\_\_\_\_)

PARTICULARS OF DEMAND DRAFT No. \_\_\_\_\_

Date \_\_\_\_\_ Bank \_\_\_\_\_ Branch \_\_\_\_\_

NAME OF THE BIDDER: \_\_\_\_\_

ADDRESS : \_\_\_\_\_

\_\_\_\_\_

TELEPHONE NUMBERS: \_\_\_\_\_ MOBILE \_\_\_\_\_

PAN NUMBER ; \_\_\_\_\_

\*(Address should be complete and supported with proof (attested copies of ration card, Registration certificate, voters ID, Adhar Card etc.) The bidder should always be available for receiving communications at the given address).

I/We submit my/our highest quotations for the below items offered for sale by Jawahar Navodaya Vidyalaya, Valpoi, Goa.

The following condemned items on "AS IS WHERE IS" basis.

Sl. No.	Particulars	Amount Offered (in Rs.)	Sl. No.	Particulars	Amount Offered (in Rs.)
1.	Old items –Roofing Mangalore Tiles		4	Old Furniture items	
2	Miscellaneous items		5	Scrap iron/electrical M & R items	
3	Old Utensils & bedding items		6	Computer items	
GRAND TOTAL					

2. I/we have very carefully read the terms and conditions of the offer, particularly, regarding earnest money and agree to abide by these in letter and spirit. The decision of the Principal, Jawahar Navodaya Vidyalaya, Valpoi on any dispute arising out of the offer shall be binding on me/us.

3. I/we agree to the forfeiture of the earnest money if I/we fail to comply with all or any of the terms and conditions in whole or in part as laid down in the tender enquiry, which would constitute and have force of a contract between me/us and the Principal, Jawahar Navodaya Vidyalaya, Valpoi, North Goa., if I/we am/are declared a successful bidder.

Place \_\_\_\_\_

Date \_\_\_\_\_

Signature \_\_\_\_\_

Name \_\_\_\_\_

Address: \_\_\_\_\_

Mobile No. \_\_\_\_\_